

STRENGTHERG LIMITED WARRANTY

Our Contact Details

Concept2 Pty Ltd
Trading as Concept2 Australia
ABN: 45634 541 834
Unit 2/5 Taree Street
BURLEIGH HEADS QLD 4220
Telephone number: **1800 324 872**
Email address: info@concept2.com.au

30-day in-home trial

If, within 30 days of receiving your Concept2 StrengthErg (**Goods**) purchased direct from Concept2 Australia, you are not satisfied with it for any reason, you may return it to us for a refund. The cardboard box must be retained in case you decide to return the Goods within the first 30 days. If you are not satisfied with your Goods, contact Concept2 Australia on 1800 324 872 within 30 days from the date of purchase for return and authorisation instructions. If your Goods are returned in as new condition, Concept2 will promptly refund your purchase price, excluding any freight and custom clearance fees.

Warranty

1. Our Goods come with guarantees that cannot be excluded under the Australian Consumer Law. You are entitled to a replacement or refund for a major failure and for compensation for any other reasonably foreseeable loss or damage. You are also entitled to have the Goods repaired or replaced if the Goods fail to be of acceptable quality and the failure does not amount to a major failure.
2. The benefits under this warranty are in addition to non-excludable rights and remedies that apply by law in relation to the Goods.
3. This warranty applies for the following periods:
 - 3.1 A five-year warranty for the following parts:
 - Front leg and rear foot assemblies, excluding caster wheels and plastic foot caps
 - Main metal box frame (including rear frame, side frame plates, and plastic bottom cover)
 - Monorail, excluding stainless steel track
 - Seat back and seat bottom
 - Carriage and slider structural components, excluding position adjustment components, plastic sleeves, upper and lower drive cord pulleys, and brake components
 - Foot plate and flex foot assembly
 - Mast, pull bar, push bar, and push bar cradle

- Flywheel enclosure, including inner and outer housing
- Stainless steel outlet perf and damper
- Flywheel, flywheel hub, flywheel axle, flywheel pulley, flywheel bearings
- Drive axle, drive spool, drive pulley and clutch, drive axle bearings
- Step axle, step pulley, step axle bearings
- All screws, bolts, and nuts

3.2 a period of 2 years from the date of purchase for all other parts excluding ErgLink and monitor batteries.

4. This warranty extends to the original purchaser of the product and to each transferee owner of the product during the term of the warranty.

5. We warrant that the Goods are free from defects in workmanship and materials.

6. Subject to the conditions of warranty set out below, if the Goods are defective for any reason within the applicable warranty period, we will repair or replace the Goods, or part thereof, free of charge.

7. The costs of:

7.1 freight and, if applicable, customs clearance fees;

7.2 labour for installation of any part supplied to you under warranty; are not covered by this warranty.

8. This warranty does not apply to:

8.1 damage to the finish of your Goods;

8.2 damage sustained as a result of neglect, abuse or failure to follow StrengthErg Maintenance Requirements;

8.3 failure of the Goods to conform with the warranty, which was caused by unreasonable use, including but not limited to failure by the consumer to provide reasonable and necessary maintenance;

8.4 Goods in which the consumer has failed to perform the following maintenance:

8.4.1 Check all screws for tightness, including those used for assembly.

8.4.2 Clean the monorail daily and flywheel as recommended in the maintenance section of the Product Manual.

8.5 Goods that have been fixed to the floor, or if any attempts have been made to fix the Goods to the floor;

8.6 Goods that have been disassembled or if attempts have been made to disassemble the Goods;

8.7 any Goods designated or sold as B-grade, which are sold "as is".

9. To the extent permitted by law, we will not be liable or in any way responsible for any special, indirect, incidental, or consequential loss or damage that is not reasonably foreseeable, including, without limitation, lost profits, emotional, multiple, punitive or exemplary damages or legal fees.

10. Apart from any consumer guarantees under the Australian Consumer Law, or any other applicable state or federal law, all other warranties, express or implied, and whether arising by virtue of statute or otherwise, are hereby excluded.
11. Altering the StrengthErg voids our warranty

Conditions of Warranty

1. Any warranty claim must be made within 28 days of the date upon which the defect first became known or first should have been discovered.
2. To obtain this warranty service you must register your warranty details online at www.concept2.com.au and record your serial number for future reference. The serial number is located on the back of the flywheel housing.

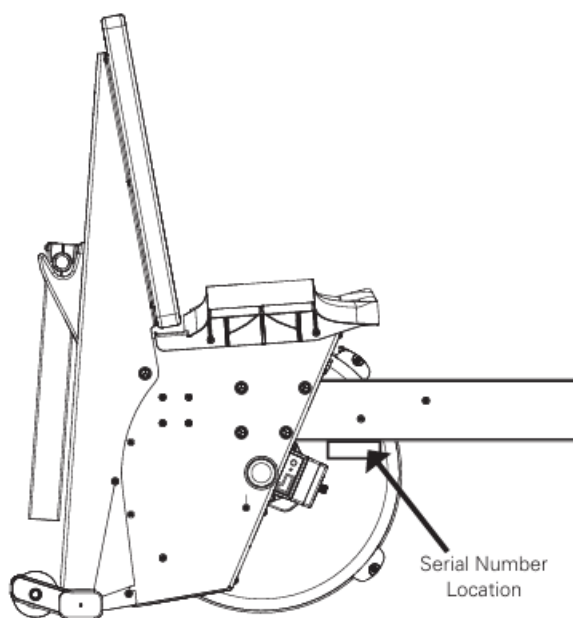

3. To make a warranty claim we require the following steps to be taken:
 - 3.1 contact Concept2 Australia by telephone (1800 324 872) to inform us of the nature of the problem.
 - 3.2 send the following to us at the address specified in this warranty:
 - 3.2.1 a letter setting out your name, return freight address, telephone number and a brief description of how the problem occurred; and
 - 3.2.2. the defective part of the Goods.
4. Freight costs and travel expenses associated with compliance with this warranty and the repair or replacement of the Goods under warranty are the responsibility of the customer.
5. If the Goods are repaired or replaced under warranty, this warranty will apply for the duration of the unexpired portion of the original warranty.

6. No amendment to this warranty will be valid or binding unless recorded in writing and signed by our authorised officer.

7. Subject to the Australian Consumer Law and any other applicable state or federal law:
 - 7.1. we expressly disclaim any responsibility for any other warranty issued by any other party in respect to the Goods purchased from us or the specification, design, manufacture or installation thereof. All claims under warranties issued by third parties must be directed to those third parties;

Care Recommendations

The Goods should be used and maintained in accordance with the StrengthErg Maintenance Requirements, the Concept2 StrengthErg Manual and any instructions that Concept2 may issue from time to time.

Warranty Information Section - Complete this section for your records

Goods Type:			
Date of Purchase:		Invoice Number:	
Model Number:		Serial Number:	
Name on Invoice:			